



**«ЗДОРОВЫЕ ГОРОДА.
ЗДОРОВОЕ ПИТАНИЕ ДЕТЯМ»**

**СЕКЦИЯ «СОЗДАНИЕ ЗДОРОВОЙ
ГОРОДСКОЙ СРЕДЫ»**

МИРОВЫЕ АКТИВНОСТИ

**РИНАТ ГАЛИЕВ
EVOLUTION, КАЗАНЬ**



АНГЛИЯ

**ИНФРАСТРУКТУРА
ВЗАИМОДЕЙСТВИЕ
«ВЛАСТЬ-ОБЩЕСТВО-КРЕАТИВ»**



ОЖИРЕНИЕ
ЗАГРЯЗНЕНИЕ ВОЗДУХА
ПРОБКИ
£1,3 МЛРД В ГОД
250 МЛН ПОЕЗДОК

Bee Network



Greater Manchester's cycling and walking infrastructure proposal

tfgm.com/Bee-Network
#BeeNetwork

ANDY BURNHAM
MAYOR OF
GREATER
MANCHESTER

GMCA GREATER
MANCHESTER
COMBINED
AUTHORITY

 Transport for
Greater Manchester

What will it look like?



Figure 18.
Example of a parallel zebra crossing



Figure 22.
Example of segregated cycle track



Figure 19.
Example of pedestrian priority



Figure 20.
Example of placemaking on a busier road



Figure 21.
Example of a SUDS segregated cycle track



Figure 23.
Example of a place being created to socialise and relax



Figure 24.
Example of a footpath level cycle track

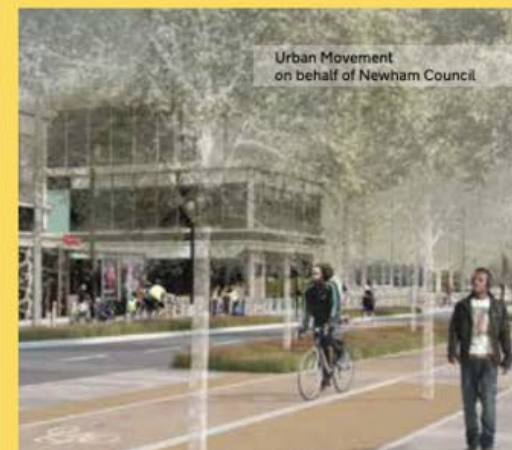



3,5X ПЕШЕХОДОВ
ВЕЛОСИПЕДИСТОВ

2 500 000 ПЕРЕМЕЩЕНИЙ
БЕЗ АВТОМОБИЛЯ

-735 000 КМ ПРОБЕГ
АВТОМОБИЛЕЙ

2X СНИЖЕНИЕ ВРЕМЕНИ
В ДОРОГЕ

£6,7 МЛРД ЭКОНОМИЧЕСКИЙ
ЭФФЕКТ

£1,5 МЛРД СТОИМОСТЬ
РЕАЛИЗАЦИИ



БРАЗИЛИЯ

ЗДРАВООХРАНЕНИЕ

ВЗАИМОДЕЙСТВИЕ

«ВЛАСТЬ-БИЗНЕС-КРЕАТИВ»

TO PREVENT SKIN CANCER,
WE ASKED FOR THE HELP
OF THOSE WHO ARE CLOSEST
TO THE PEOPLE'S SKIN.

BACKGROUND

BRAZILIAN BEACH CULTURE IS UNIQUE.
BEAUTIFUL TANNED BODIES, COOL TATTOOS, BUT ALSO SKIN CANCER.
THERE ARE 140,000 NEW CASES DIAGNOSED EACH YEAR
WITH AN INCREASE OF 74% IN PEOPLE UNDER THE AGE OF 40.

IN ORDER TO MAKE YOUNG PEOPLE AWARE OF THIS PROBLEM, SOL DE JANEIRO,
A YOUTH SUNSCREEN BRAND, FOUND A NEW WAY TO PREVENT SKIN CANCER.

IDEA

WE ASKED FOR THE HELP OF THOSE WHO ARE CLOSEST TO THE SKIN OF
YOUNG PEOPLE IN BRAZIL: THEIR TATTOO ARTISTS.

IN BRAZIL THERE ARE OVER 25 MILLION PEOPLE WITH TATTOOS.

IN PARTNERSHIP WITH A.C. CAMARGO, ONE OF THE MOST RESPECTED
CANCER INSTITUTES IN THE WORLD, WE CREATED A TRAINING PROGRAM
THAT TEACHES TATTOO ARTISTS HOW TO RECOGNIZE SKIN PROBLEMS.

DR. JOÃO P. DUPRAT NETO
DIRECTOR OF THE CENTER FOR SKIN CANCER



A DIPLOMA CERTIFIES THE TATTOO ARTIST'S
PARTICIPATION IN THE CLASS

RESULTS

OVER 450 TATTOO ARTISTS CERTIFIED FROM ALL OVER BRAZIL.

MORE THAN 10,000 NEW SKIN CANCER CHECKS EVERY WEEK.

THANKS TO THEIR TATTOO ARTISTS, MANY PEOPLE THAT HAD NEVER VISITED
THE DERMATOLOGIST HAD AN EARLY SKIN CANCER DIAGNOSIS.

SOL DE JANEIRO CONSOLIDATED ITSELF AS THE SUNSCREEN BRAND THAT
REALLY TAKES CARE OF YOUNG PEOPLE'S SKIN IN BRAZIL.

THE PROJECT WAS FEATURED IN THE MAIN NATIONAL NEWS PROGRAMS AND
THOUSANDS OF BLOGS.

SERGIO LEO'S
TATTOO ARTIST



WATCH THE VIDEO AT:
SKINEMELIHEASROLL.COM/TATTOO

10 500

ТАТУ-МАСТЕРОВ

440 000

ЧЕКАПОВ В НЕДЕЛЮ

100+

СПАСЕННЫХ ЖИЗНЕЙ





ФРАНЦИЯ

ИНФРАСТРУКТУРА
ВЗАИМОДЕЙСТВИЕ
«ВЛАСТЬ-ОБЩЕСТВО-КРЕАТИВ»

PARIS PLAGES

Parc Rives de Seine

Ouverture des plages
TOUS LES JOURS À PARTIR
DE 10H JUSQU'À 19H

Ludomou'w

ACTIVITÉS ENFANTS • Venez découvrir cet espace de jeux ouverts à tous, parents et enfants, animés par des professionnels de l'enfance de la Ville de Paris. Jeux de société ou jeux de construction, il y en aura pour tous les goûts !
DU LUNDI AU SAMEDI DE 14H À 19H

Jardin de Brème

Rafraîchissez-vous dans un espace de parbrumes arboré de plantes aquatiques pour un moment de détente absolue !
TOUS LES JOURS DE 10H À 18H



LES HALLES

Altermandi

TOUS LES JOURS DE 11H À 14H ET DE 15H À 19H30

Baby-foot

SPORTS ET DÉTENTE
TOUS LES JOURS DE 13H À 20H

Les Jeux Géants

SPORTS ET DÉTENTE
Prêts de jeux de société grand format
TOUS LES JOURS DE 11H À 19H
DERNIERS PRÊT 18H30

Défibrillateur Tuileries



Maison Maison

LE LUNDI DE 15H À 02H
DU MARDI AU DIMANCHE DE 12H À 24H

Spot fraîcheur

Venez vous rafraîchir assis sur un banc connecté au réseau fraîcheur de la ville de Paris.
TOUS LES JOURS

Scilicet

TOUS LES JOURS DE 14H À 22H30

La Table de Cana

TOUS LES JOURS DE 11H À 22H



CHÂTELET

Escale Batobus



Tartine en Seine

TOUS LES JOURS DE 9H À 23H

Poste de Secours

VENDREDI ET SAMEDI DE 17H À 22H
DIMANCHE DE 14H À 20H

Boulodrome

SPORTS ET DÉTENTE
TOUS LES JOURS DE 8H À 24H

Bibliothèque Hors les Murs

CULTURE • Les bibliothèques Arthur Rimbaud, Forney et la bibliothèque historique de la Ville de Paris, s'associent à la Ludomou'w « des Célestins » pour vous proposer des séances de lecture et découverte.
EN JUILLET, LES MARDIS ET JEUDIS DE 14H30 À 17H30

Ludomou'w

DU LUNDI AU SAMEDI DE 14H À 19H



SULLY MORLAND

Velettes de Paris N^o. Pélican

TOUS LES JOURS DE 12H À MINUIT

Gym Suédoise

Durée : Entre 45 mn et 1 h
LUNDI 19H : INTENSIF
MERCREDI 19H : STANDARD
SAMEDI 11H : INTENSIF
DIMANCHE 17H : STANDARD

Mozza & co

TOUS LES JOURS DE 11H À MINUIT

Food Breizh

TOUS LES JOURS DE 11H À 23H

Yoga

Durée : 1 h
TOUS LES DIMANCHES DE 11H À 12H

Arts Énergétiques

SPORTS ET DÉTENTE • Pour un réveil tonique, retrouvez tous les matins les cours de Tai Chi, de Do In ... encadrés par l'association Créasens
TOUS LES JOURS DE 10H À 12H

Danse

SPORTS ET DÉTENTE • Venez découvrir un style de danse différent chaque soir. Le dimanche après-midi les plus jeunes pourront retrouver le bal des enfants.
DU LUNDI AU VENDREDI DE 17H À 20H
LE SAMEDI DE 18H À 21H
LE DIMANCHE DÈS 15H BAL DES ENFANTS

SoliCycle

Atelier réparation et animations autour du vélo.
DU MARDI AU DIMANCHE

Défibrillateur Quai Hôtel de Ville

Paris qui sauve

Venez apprendre à sauver une vie en quelques gestes ! Paris qui sauve vous propose, en partenariat avec la Protection Civile et la Croix Rouge, de venir s'initier aux gestes qui sauvent gratuitement. Une session de 45 minutes par heure. Inscription sur Parisplages.fr.
DU LUNDI AU SAMEDI DE 14H À 17H

Les Magnereaux

DU MARDI AU VENDREDI DE 17H À 24H. LES SAMEDIS ET DIMANCHE DE 12H À 24H

Les Nautas

DU LUNDI AU VENDREDI DE 17H À 24H
LES SAMEDIS ET DIMANCHE DE 13H À 24H.

Le Mousquet

TOUS LES JOURS DE 11H À 24H

Défibrillateur Pont de Sully



BRUMISATEUR



TOILETTES



POINT INFORMATION



BOIRE & MANGER



GLACIER



MÉTRO



ESPACE DÉTENTE



ESPACE PIQUE-NIQUE



FONTAINE
EAU DE PARIS



ESCALE



ВОЛЛЕЙБОЛ

ФУТБОЛ

ПЕТАНК

ПИНГ-ПОНГ

КИНО НА ВОДЕ

КОНЦЕРТЫ





ИТАЛИЯ

**ЗДРАВООХРАНЕНИЕ
ВЗАИМОДЕЙСТВИЕ
«ВЛАСТЬ-ОБЩЕСТВО-КРЕАТИВ»**



**l'Italia rinasce
con un fiore
vaccinazione
anti-Covid 19**

ENERGY SELF-SUFFICIENCY

**SELF-SUPPORTING
FABRIC PARTITIONS**

WOODEN FRAME

FABRIC EXTERNAL COVER

**CENTRAL CORE WITH
TECHNICAL SYSTEM/PLANT**

WOODEN BASE

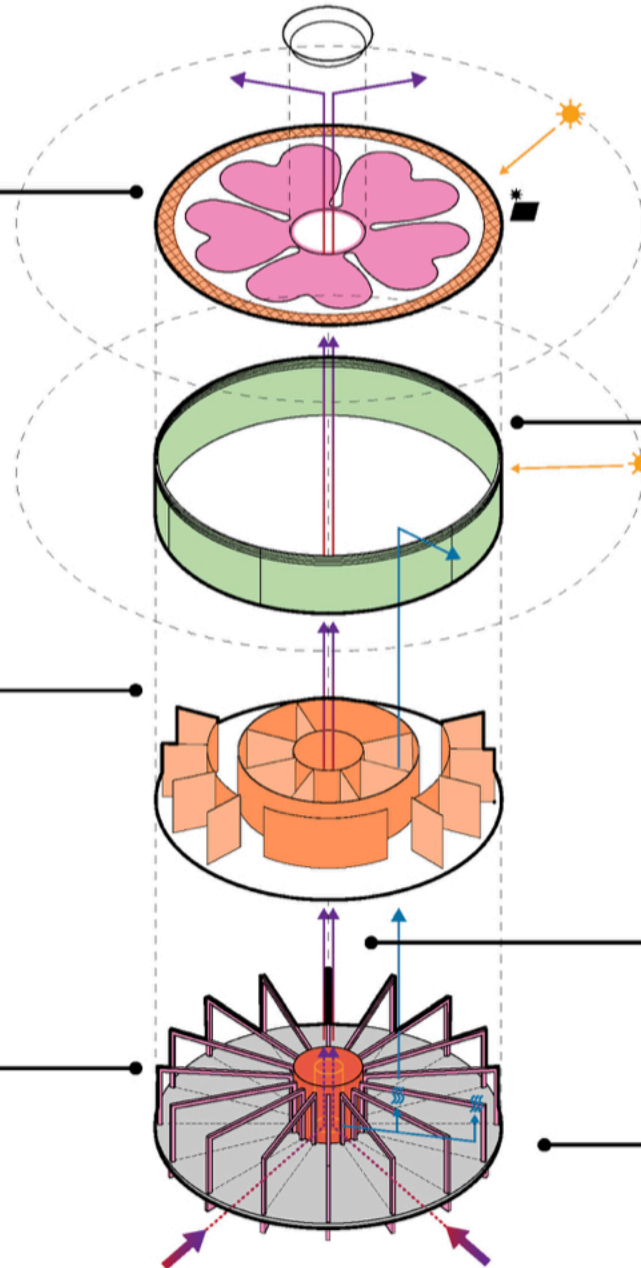



2 642 ПУНКТА

33 МИЛЛИОНА ДОЗ ВАКЦИН

11 МИЛЛИОНОВ ЧЕЛОВЕК



ИРЛАНДИЯ

ИНФРАСТРУКТУРА
ВЗАИМОДЕЙСТВИЕ
«ВЛАСТЬ-ВОЛОНТЕРЫ-ОБЩЕСТВО»

95 000 ЖИТЕЛЕЙ

1 700 ВОЛОНТЕРОВ

1 000± ЗВОНКОВ В ДЕНЬ

ОБРАЗОВАНИЕ

ПСИХОЛОГИЧЕСКАЯ

ПОДДЕРЖКА







**«НЕСМОТРЯ НА ТО, ЧТО
МЫ ОТДАЛИЛИСЬ
ДРУГ ОТ ДРУГА,
МЫ НИКОГДА ЕЩЕ
НЕ БЫЛИ ТАК БЛИЗКИ»**



**«ЗДОРОВЫЕ ГОРОДА.
ЗДОРОВОЕ ПИТАНИЕ ДЕТЯМ»**

**СЕКЦИЯ «СОЗДАНИЕ ЗДОРОВОЙ
ГОРОДСКОЙ СРЕДЫ»**

**МИРОВЫЕ
АКТИВНОСТИ**

**РИНАТ ГАЛИЕВ
EVOLUTION, КАЗАНЬ**